

VRT60X2

DATASHEET

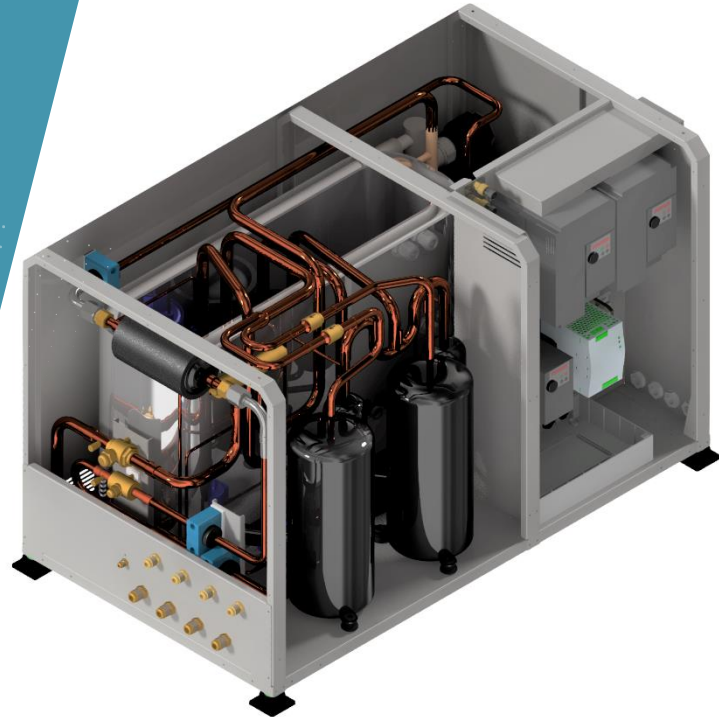

Cooling capacity KW	min 6	std 54	max 60
Cooling power source KW	min 2	std 8,5	max 16
Heating capacity KW	min 6	std 54	max 60
Heating power source KW	min 2	std 8,5	max 16

Total BTU Capacity:
Power supply:

Comparable to 205.000 BTU/h of the competitors.
180 - 230Vac / 50-60Hz 1ph
380 - 440 Vac / 50-60 Hz 3ph (VRT60X2-4V)
700 Vdc (VRT60X2-7V) on request

Sea water pump:

Magnetic type. Centrifugal 400lt/min 1,2kw included in unit power consumption.

Size W x D x H:

1178 x 660 x 697 mm

Weight:

190 Kg

Sea water working range:

+3°C to +40°C

Air working range:

-20°C to +50°C

Noise:

Compressor @ 140 hz – 73db @ 1 meter from box

Vibration:

No significant vibration transmitted to the feet

Sea water pipes connection:

1" 1/2

Refrigerant pipe:

4 x 5/8" Gas

4 x 1/2" Liquid

Compressor box use VRV inverter architecture with refrigerant circulation inside air handler
Databus rs485 modbus on board

System based on Toshiba VFD and twin rotary compressor



CONDENSER:

Titanium Grade 2. No fouling, no corrosion. 3 times lighter than copper nickel



COMPRESSOR:

Toshiba inverter twin rotary. COP > 4

Rotation speed: 600 to 6000 rpm



FRAME:

Stainless Steel 316



SOFTWARE MANAGEMENT:

Compressor high temperature, low temperature, high pressure condenser, low pressure compressor, electronic pressure gas, electronic pressure liquid, Condensation control, Evaporation control



COMPRESSOR PROTECTION:

Over/undervoltage, overcurrent, torque, winding temperature, stepout (bad lubrication), power input, power output, efficiency, overload, oil level (with EEV)



ELECTRONIC:

Microprocessor board with rs485 modbus rtu communication. Interface to Termodinamica air handling unit or fresh air unit

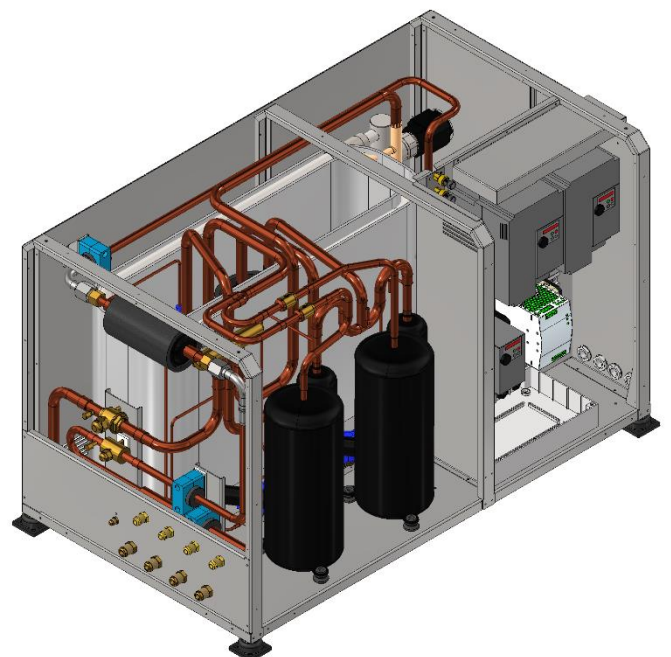
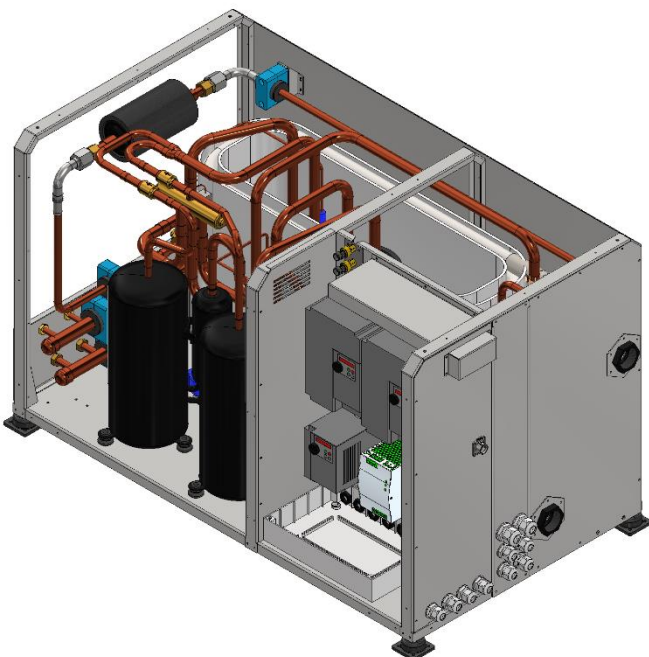

VRT60X2

PERFORMANCE CURVE DC INVERTER 70 rps/ 100

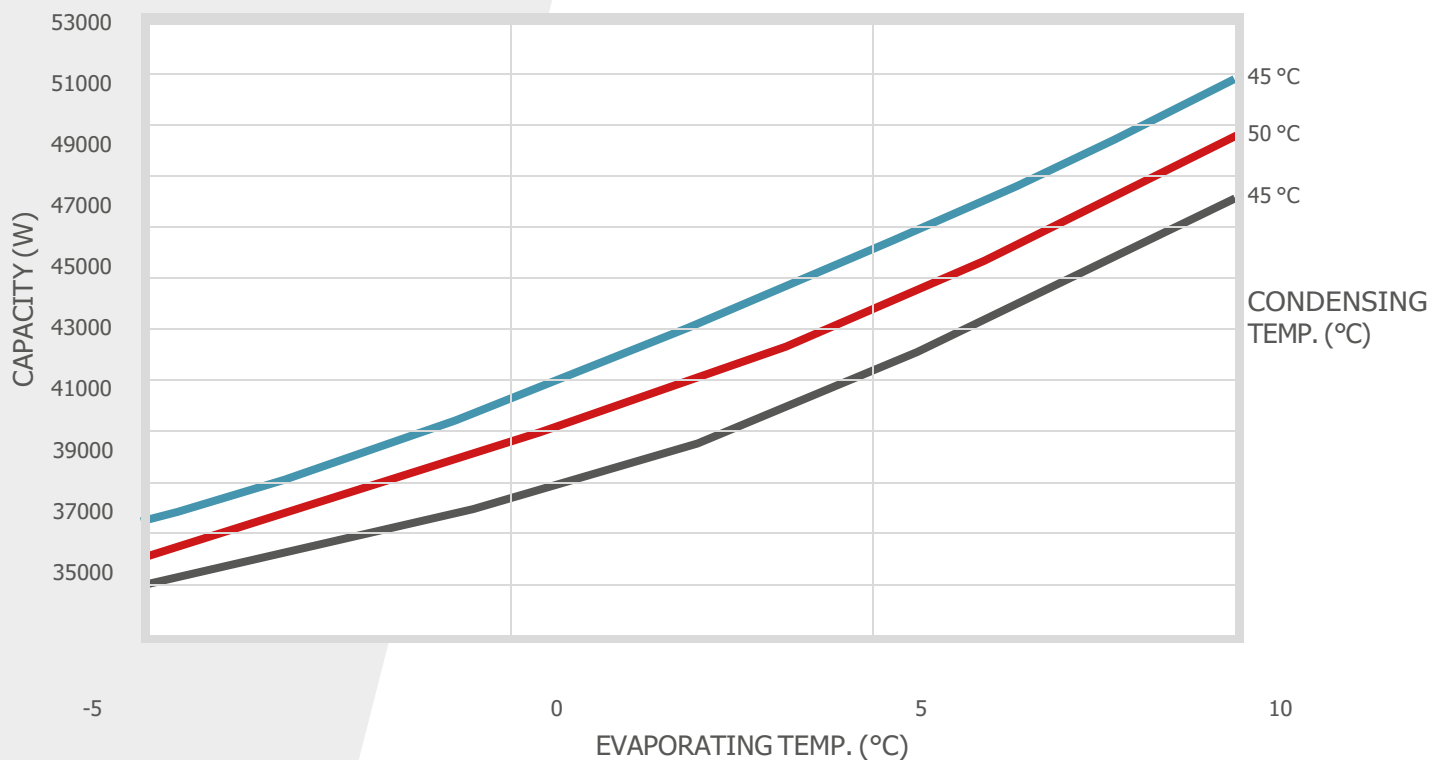
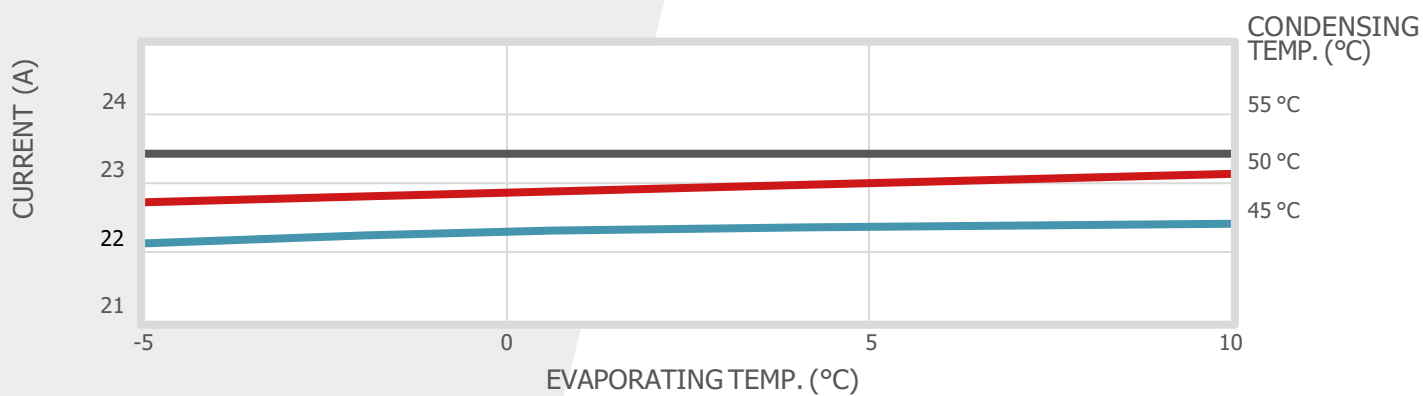
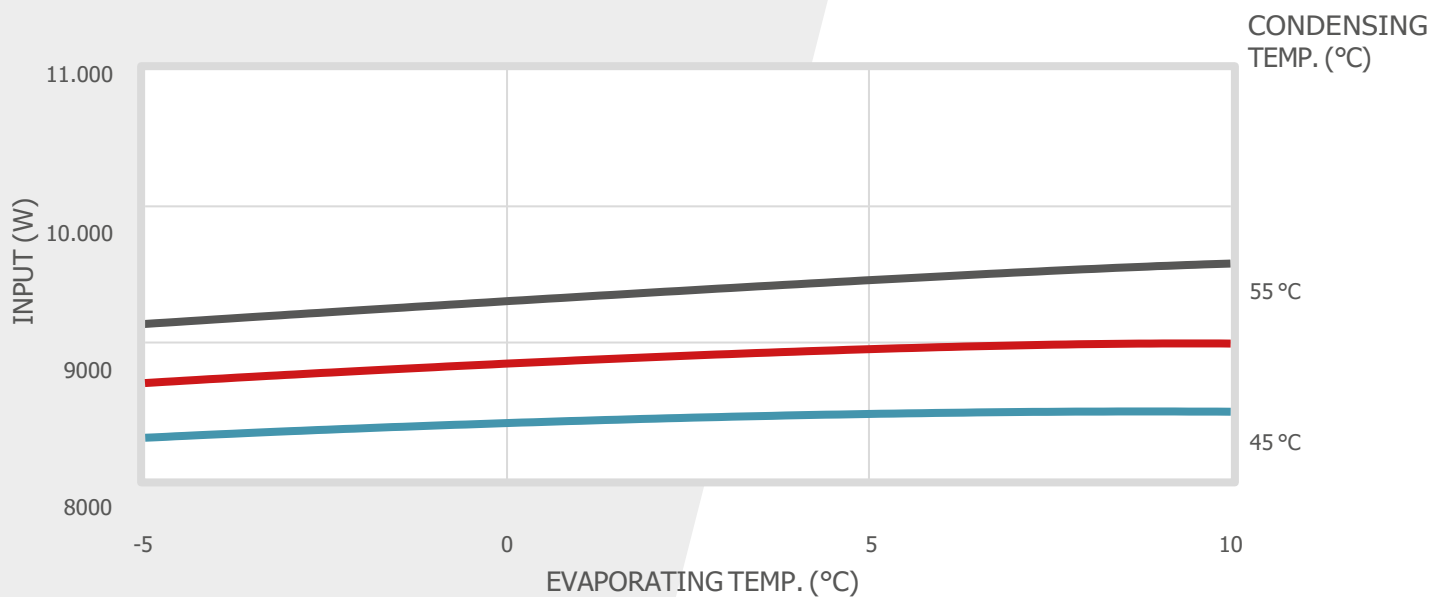



VRT60X2 ELECTRICAL CONNECTION

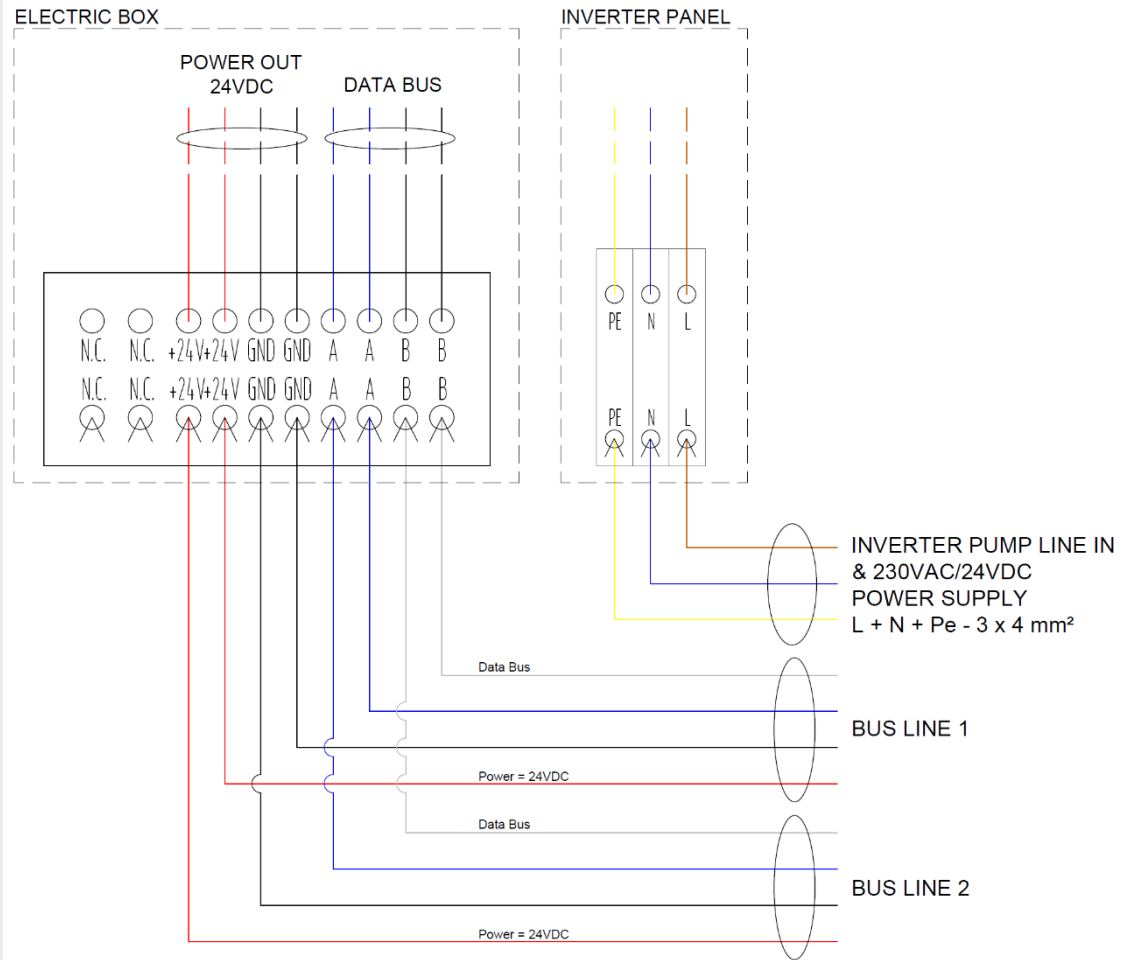

VRT60X2-4V – VRT50X2-7V ELECTRICAL CONNECTION

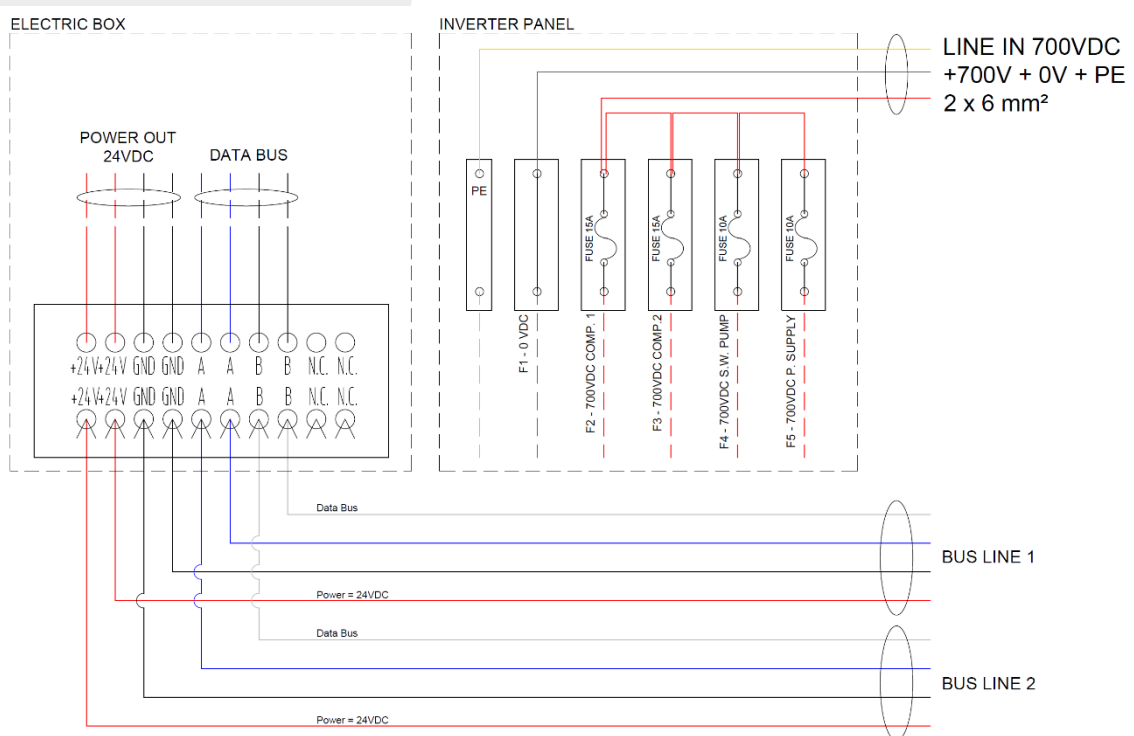

VRT60X2

OVERALL DIMENSIONS

